

APPROVAL REQUIRED	PLEASE VERIFY	DRAWING NOTES
<input type="checkbox"/> APPROVED AS DRAWN	1. PLEASE SELECT ALUMINUM ANODIZE COLOR: <input type="checkbox"/> CLEAR <input type="checkbox"/> DARK BRONZE	1. THIS WILL BE FABRICATED & SHIPPED TO THE EXACT DIMENSION SHOWN.
<input type="checkbox"/> APPROVED AS NOTED	2. PLEASE SELECT GLAZING RATING: <input type="checkbox"/> U.L. LEVEL 1 <input type="checkbox"/> U.L. LEVEL 2 <input type="checkbox"/> U.L. LEVEL 3	2. ALL DIMENSIONS MUST BE APPROVED, SIGNED, DATED, OR OTHERWISE NOTED ON THIS DRAWING BEFORE FABRICATION CAN BEGIN.
<input type="checkbox"/> REJECTED	3. PLEASE SELECT GLAZING MATERIAL TYPE: <input type="checkbox"/> UNCOATED ACRYLIC (LVL 1 & 2 ONLY) <input type="checkbox"/> ABRASION RESISTANT ACRYLIC (LVL 1 & 2 ONLY) <input type="checkbox"/> LAMINATED POLYCARB./ACRYLIC (LVL 1, 2, & 3) <input type="checkbox"/> GLASS CLAD POLYCARBONATE (LVL 1, 2, & 3)	3. FINISHED OPENING SIZE: 36 1/4" x 36 1/4".
SIGNATURE:	CONTACT T.S.S. FOR LEVEL 4-5 & 7-8 OPTIONS (LEVEL 3 MEETS LEVEL 6 REQUIREMENTS)	4. VOICE PORT WILL BE CENTERED IN UNIT, UNLESS OTHERWISE SPECIFIED (TYP. 60" A.F.F.).
DATE:		5. ALUMINUM COLOR MUST BE SPECIFIED FOR THE ENGINEERING TO BEGIN.
		* IN THE EVENT OF CONFLICTS OR DISCREPANCIES AMONG THE CONTRACT DOCUMENTS, INTERPRETATIONS WILL GIVE PRIORITY TO THE TOTAL SECURITY SOLUTIONS APPROVAL DRAWINGS OVER THE PROPOSAL OR ANY OTHER DOCUMENT PROVIDED OR INCLUDED IN THE AGREEMENT.

() UNIT(S) REQUIRED

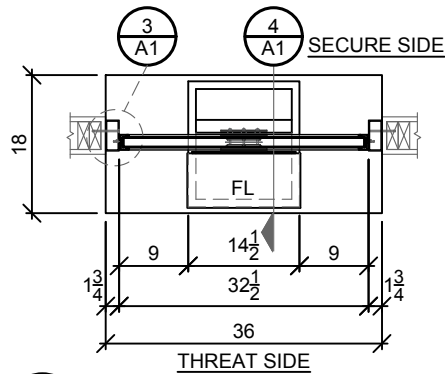

1 PLAN
A1

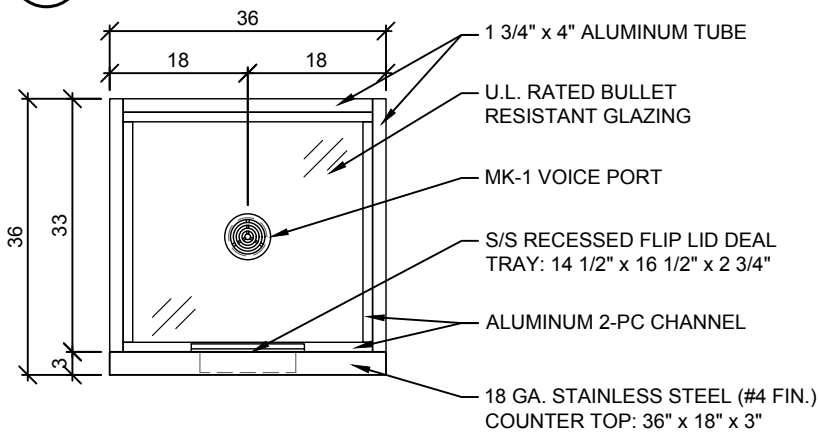

2 ELEVATION
A1

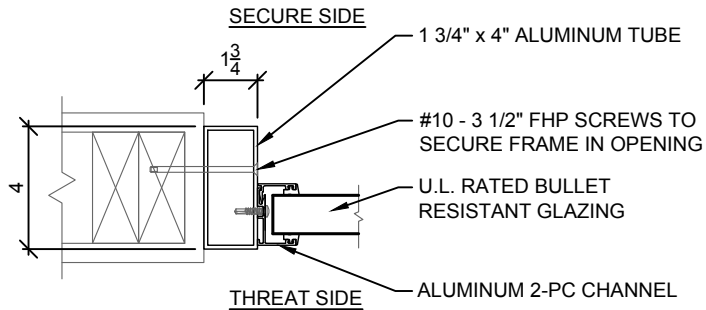

3 DETAIL
A1

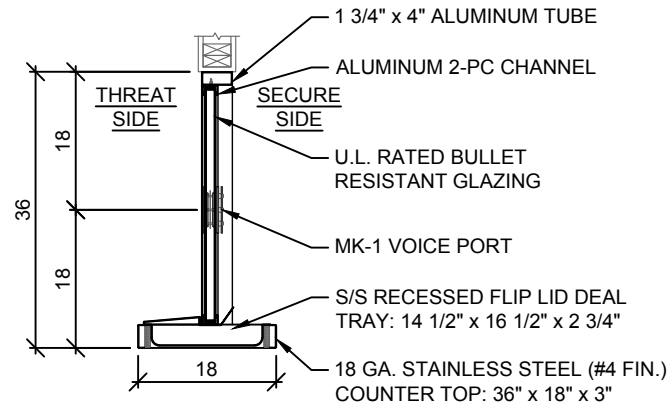

4 SECTION
A1

SHEET NUMBER:	A1
DATE:	01.01.12
DRAWN BY:	XXX
ENG. BY:	YYY
CHECKED BY:	XX
REVISIONS:	
DATE	DESCRIPTION

PROJECT NAME: EXTERIOR TRANSACTION WINDOW WITH SIS COUNTER TOP & FLIP LID DEAL TRAY MK-1 VOICE PORT

The information in this drawing is confidential and is the property of TOTAL SECURITY SOLUTIONS. When reproducing or for distribution from TOTAL SECURITY SOLUTIONS.

Total Security Solutions
170 National Park Drive
Fowlerville, MI 48836
Phone: 517.223.7807 Fax: 517.223.0805
www.DemandTSS.com

TOTAL SECURITY SOLUTIONS