

APPROVAL REQUIRED	PLEASE VERIFY	DRAWING NOTES
<input type="checkbox"/> APPROVED AS DRAWN	1. PLEASE SELECT GLAZING RATING: <input type="checkbox"/> U.L. LEVEL 1 <input type="checkbox"/> U.L. LEVEL 2 <input type="checkbox"/> U.L. LEVEL 3	1. THIS WILL BE FABRICATED & SHIPPED TO THE EXACT DIMENSION SHOWN.
<input type="checkbox"/> APPROVED AS NOTED	<input type="checkbox"/> U.L. LEVEL 4 <input type="checkbox"/> U.L. LEVEL 5 <input type="checkbox"/> U.L. LEVEL 6	2. ALL DIMENSIONS MUST BE APPROVED, SIGNED, DATED, OR OTHERWISE NOTED ON THIS DRAWING BEFORE FABRICATION CAN BEGIN.
<input type="checkbox"/> REJECTED	<input type="checkbox"/> U.L. LEVEL 7 <input type="checkbox"/> U.L. LEVEL 8	3. FINISHED OPENING SIZE: 36 1/4" x 36 1/4".
SIGNATURE:	2. PLEASE SELECT GLAZING MATERIAL TYPE: <input type="checkbox"/> UNCOATED ACRYLIC (LVL 1 & 2 ONLY) <input type="checkbox"/> ABRASION RESISTANT ACRYLIC (LVL 1 & 2 ONLY) <input type="checkbox"/> LAMINATED POLYCARB./ACRYLIC (LVL 1, 2, & 3) <input type="checkbox"/> GLASS CLAD POLYCARBONATE (LVL 1 - 8)	4. VOICE PORT WILL BE CENTERED IN UNIT, UNLESS OTHERWISE SPECIFIED (TYP. 60" A.F.F.).
DATE:	3. PLEASE SELECT COUNTER TOP MATERIAL: <input type="checkbox"/> BLACK PLASTIC LAMINATE <input type="checkbox"/> 18 GA. S/S - #4 FIN.	* IN THE EVENT OF CONFLICTS OR DISCREPANCIES AMONG THE CONTRACT DOCUMENTS, INTERPRETATIONS WILL GIVE PRIORITY TO THE TOTAL SECURITY SOLUTIONS APPROVAL DRAWINGS OVER THE PROPOSAL OR ANY OTHER DOCUMENT PROVIDED OR INCLUDED IN THE AGREEMENT.

() UNIT(S) REQUIRED

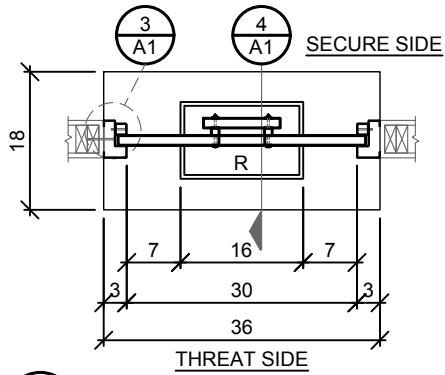

1 PLAN
A1

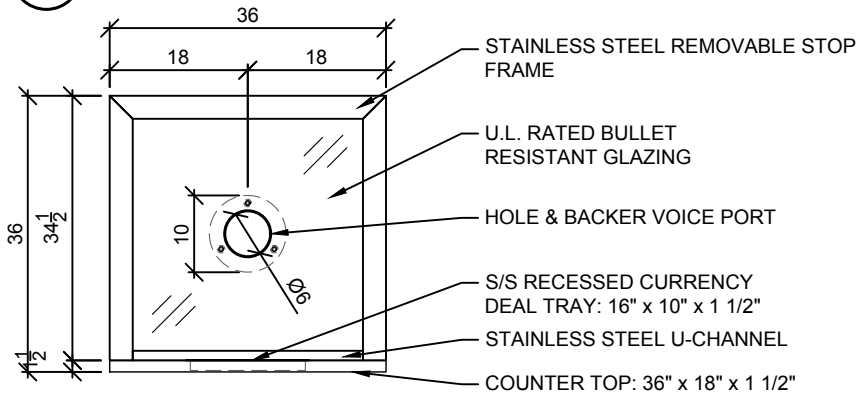

2 ELEVATION
A1

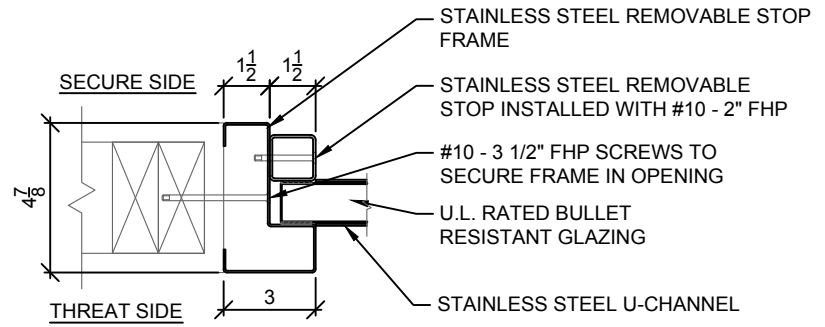

3 DETAIL
A1

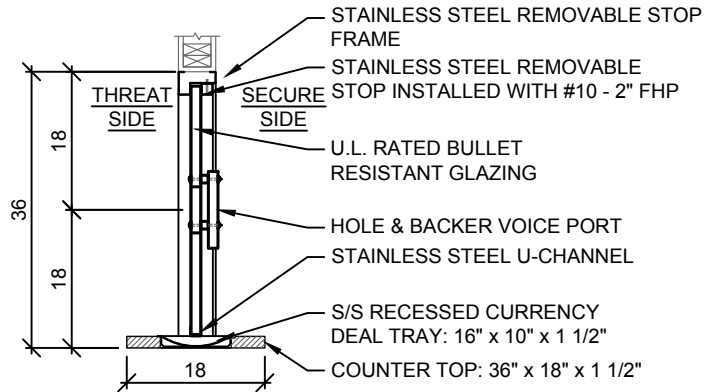

4 SECTION
A1

SHEET NUMBER:	A1	
PROJECT TITLE:	DETAILS	
DATE:	01.01.12	
DRAWN BY:	XXX	
ENG. BY:	YYY	
CHECKED BY:	XX	
REVISIONS:		
NO.	DATE	DESCRIPTION
1		
2		
3		
4		
PROJECT NAME:	STAINLESS STEEL HOLLOW METAL TRANSACTION WINDOW WITH COUNTER TOP & S/S RECESSED DEAL TRAY HOLE & BACKER VOICE PORT	
<small>The information in this drawing is confidential and is the property of TOTAL SECURITY SOLUTIONS. When reproduced or used for any purpose without the prior written permission of TOTAL SECURITY SOLUTIONS, it is strictly prohibited.</small>		
Total Security Solutions 170 National Park Drive Fowlerville, MI 48836 Phone: 517.223.0807 Fax: 517.223.0805 www.DemandTSS.com		
TOTAL SECURITY SOLUTIONS		